

**C.I.P.****222 Rem.**

TAB.

I

Date

84-06-14

Révision

08-09-13

Pays d'origine: US

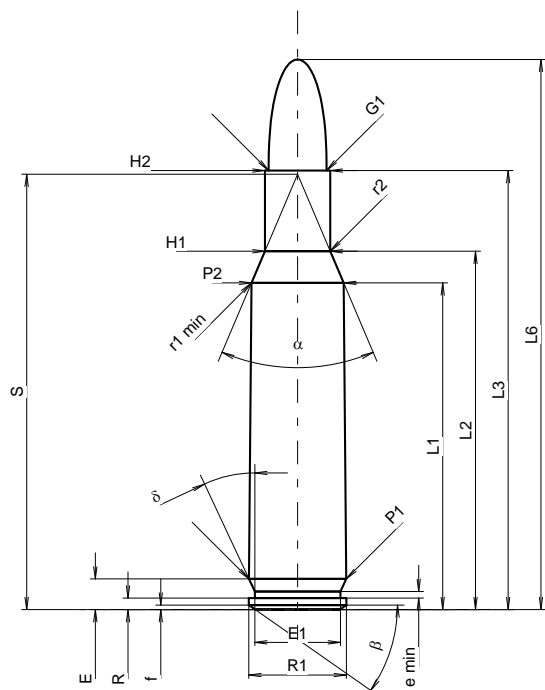
**CARTOUCHE MAXI****Longueurs**

L1 <sup>1)</sup>	=	32.13	-0.20
L2 <sup>1)</sup>	=	35.24	-0.20
L3 <sup>1)</sup>	=	43.18	
L4	=		
L5	=		
L6	=	54.10	

**Culot**

R	=	1.14	
R1	=	9.60	
R3	=		
E	=	3.01	
E1	=	8.43	
e min	=	0.64	
delta	=	25°	
f	=	0.45	
beta	=	35°	

**Chambre à poudre**

P1	=	9.58	
P2 <sup>1)</sup> *	=	9.07	-0.20

**Cône de raccordement**

alpha <sup>*</sup>	=	46°	
S <sup>*</sup>	=	42.81	
r1 min	=	0.64	
r2	=	2.54	

**Collet**

H1 <sup>*</sup>	=	6.43	
H2 <sup>1)</sup>	=	6.43	

**Projectile**

G1 <sup>1)</sup>	=	5.70	
G2	=		
F	=		
L3+G <sup>1)</sup>	=	45.37	

**Pressions (Énergies)****Méthode transducteur**

Pmax	=	3700 bar	
PK	=	4255 bar	
PE	=	4625 bar	
M	=	25.00	
EE	=	1810 Joule	

**Autres indications**

Fe <sup>1)3)</sup>	=	0.15	
delta L	=	0.08	

**CHAMBRE MINI****Longueurs**

L1	=	32.01	
L2	=	35.10	
L3 <sup>1)</sup>	=	43.48	

**Cuvette**

R	=		
R1	=	9.66	
R2	=		
R3	=		
r	=		

**Chambre à poudre**

E	=	3.01	
P1 <sup>1)</sup>	=	9.61	
P2 <sup>*</sup>	=	9.10	

**Cône de raccordement**

alpha <sup>1)</sup> *	=	46°	
S <sup>*</sup>	=	42.74	
r1 max	=	0.64	
r2	=	3.18	

**Collet**

H1 <sup>*</sup>	=	6.48	
H2 <sup>1)</sup>	=	6.45	

**Prise de rayures**

G1 <sup>1)</sup> *	=	5.69	
G <sup>1)</sup>	=	2.191	
alpha l	=	90°	
h	=	0.38	
s <sup>*</sup>	=	1.02	
i <sup>1)</sup> *	=	3°10'36"	
w	=		

**Canon**

F <sup>1)</sup> *	=	5.56	
Z <sup>1)</sup>	=	5.69	

**Rayures**

b	=	2.03	
N	=	6	
u	=	356.00	
Q	=	25.09	mm <sup>2</sup>

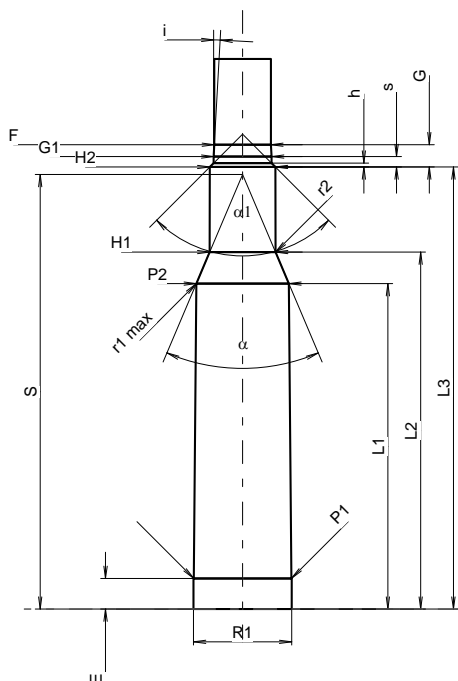

Échelle 1.35:1

Dimensions en << mm >>  
Dimensions et tolérances pour les canons  
d'épreuve: Voyez Annexe CR 1.

Notes: 1) A' contrôler pour la sécurité  
3) Feuillure sur la cone de raccordement  
\* Dimensions de base